

# 505DE Digital Control System

## for Single Valve, Single Extraction / Admission or Dual Extraction / Admission Steam Turbines

### Application

The 505DE controller is designed to operate industrial steam turbines of all sizes and applications. This steam turbine controller includes specifically designed algorithms and logic to start, stop, control, and protect industrial steam turbines driving generators or compressors. The 505DE control's unique PID structure makes it ideal for applications where it is required to control steam plant parameters like turbine speed, load, and inlet, extraction, or exhaust header pressures. This configurable controller allows users to configure it for use on single inlet turbines, single extraction turbines, or double extraction turbines, making it ideal for plants wanting to standardize on one product for all their steam turbines.

The 505DE controller senses turbine speed via single or multiple, passive or active, speed probes and controls the steam turbine and its related headers through one, two, three, or four valve driver outputs connected to the turbine inlet and extraction steam valves. The control's special PID-to-PID logic allows stable control during normal turbine operation and bumpless control mode transfers during plant upsets or on steam map limits, minimizing process over- or undershoot conditions.

For critical applications requiring increased reliability and redundancy, users can select dual-redundant control models, which have manual switch-over and automatic fail-over logic. These redundant control models use proven redundancy manager algorithms to ensure bumpless transfers and that system operation is not affected by single point failures. With a dual-redundant configured 505DE control, the two CPU modules operate in a master/slave manner, using synchronized memory to increase overall system availability. This configuration allows for automatic and/or manual transfers between the two sets of modules in cases of external I/O, internal module, or input power failures. Redundancy manager logic also allows the configuration and selection of multiple input parameter signals via high-signal-select and low-signal-select logic.

### Description

The 505DE is built on Woodward's field-proven MicroNet™ Plus platform, with integral application software that is designed and user-configurable to control:

- Single valve steam turbines
- Split-range valve steam turbines
- Single extraction/admission steam turbines
- Double extraction/admission steam turbines
- Double extraction/admission steam turbines (with dual inlet valves)

The 505DE controller is available with an 8-Slot or 14-slot MicroNet chassis designed to be bulkhead-mounted in a cabinet or control panel, and contains the required I/O and core control software to control industrial steam turbines. Typically, this controller is located in an enclosure that is rated for the site-specific environment requirements. Field Termination Modules (with integrated circuit fuse protection) are included with this controller to allow users to easily land and manage turbine and system interface wiring. The control also supplies source power for associated turbine sensors and I/O circuits.



- Field-configurable for:
  - ✓ Single valve turbines
  - ✓ Single extraction / admission turbines
  - ✓ Double extraction / admission turbines
- Simplex or dual redundant models
- Integrated turbine control and protection
- Automatic start/stop routines
- OEM qualified algorithms
- Four ratio/limiter de-coupling modes
- Based on popular 505E control
- User-friendly interface
- Ethernet or serial com ports
- Optional 38 cm (15") touchscreen HMI
- Easily interfaces to plant DCS

Depending on the application requirements, the 505DE control is available with a short (8-slot) or long (14-slot) chassis. The 505DE short chassis models are designed for systems where only proportional actuator drive signals are required (0–100% valve demands). Alternatively, an external Servo Position Controller (SPC) can be used with the 505DE short chassis models to interface with integrating-type servo actuators. The 505DE long chassis models include special integrating driver modules and are designed for systems where one or more integrating servo-drive output signals are required (uni-polar or bipolar action, requiring a null current).

The 505DE control is field configurable. A menu-driven software program (PCI Tool) is provided with the control, and when installed on any Windows based computer or laptop, serves as the human interface. This PCI Tool is used to configure, service, and optionally operate the control/turbine. An optional 38 cm (15") OpView™ panel is available for use as a local or remote operator control panel or engineering workstation. This OpView panel connects to the control via an Ethernet link, and once connected, self configures its screens based on the 505DE control's configuration settings.

This controller's architecture is patterned after the popular 505E Single Extraction/Admission Steam Turbine Control. The control can be configured to operate as a stand-alone unit or in conjunction with a plant's Distributed Control System. The 505DE is API 612 compliant and designed for installation and use in petroleum and chemical plants.

## Control Functions

The 505DE can be configured to operate different types of turbines. Listed below are the functions available with each configuration:

### Single Valve Turbines:

- Start/Stop Sequencing with idle speed hold points
- Speed PID Control
- Cascade Control (Pressures, loads, etc.)
- Aux-1 Limiter or Controller PID (pressures, loads, etc)
- Aux-2 Limiter or Controller PID (pressures, loads, etc)
- Valve Limiters (single or split range)
- Critical Speed Avoidance
- Overspeed Protection
- Alarm and Shutdown Protection Logic
- Serial and Ethernet Modbus® \* Communications
- Redundant CPU, Power Supplies & I/O with auto selection
- Integrating Valve Controller (with 2-Chan Act module)

\*—Modbus is a trademark of Schneider Automation Inc.

### Single Extraction Turbines:

- All functions listed under Single Valve Turbines
- Extraction/Admission PID Control
- Valve Ratio/Limiter Protection
- Automatic Ratio/Limiter mode selection (load or ext/adm)

### Double Extraction Turbines:

- All functions listed under Single Extraction Turbines
- P1 Extraction/Admission PID Control
- P2 Extraction/Admission PID Control

Depending on the application, the following configurable functions are provided and can be selected through a configuration menu:

- Inlet Pressure Control or Limiting
- Exhaust Pressure Control or Limiting
- Process Control or Limiting
- Bootstrap Based Starts
- Generator MW Control and Limiting
- Utility Tie-Line MW Control and Limiting
- Remote 4–20 mA or Modbus Setpoints (All PIDs)
- Overspeed Testing
- Isochronous Load Sharing (Via EGCP-3 controller)
- 4–20 mA Meter Readouts
- Relay Indication Outputs (DCS & Lamp interfaces)

In order to support the control flexibility, all inputs and outputs (I/O) are configurable by the user. Optionally, users may add I/O modules to increase unit redundancy and or increase unit I/O capacity.

## PID Functionality/Relationships

### Speed Control

The speed control receives turbine speed information from one or multiple magnetic pickups or proximity probes. The Speed PID compares the speed value against a speed reference setpoint to determine the correct turbine valve position demands. Depending on the configured application, the Speed PID output is sent directly to the valve driver(s) or ratio/limiting algorithms to set the unit valve position(s).

### Cascade & Aux Controllers

Three process control PIDs are available for use in controlling or limiting multiple system process parameters (inlet/exhaust pressures, MW, etc.). When configured, the Cascade PID is cascaded into the Speed PID's setpoint to control related system processes. The Cascade PID is ideal for load control or inlet header control, as its output can be limited to set min and max levels). When configured, the Aux-1 and Aux-2 PIDs can be configured to function as controllers (enabled/ disabled) or as limiters to protect the unit, system or plant. The Aux PIDs are ideal for low inlet header or import/export MW limiting functions.

### Extraction/Admission Controllers

Depending on unit configuration, no, one, or two Ext/Adm PIDs are used by the 505DE control. These PIDs receive their respective header pressure signal, compare it to a setpoint, and output an extraction/admission flow demand signal to the control's Ratio/Limiting algorithm to position the turbine valves to control their respective header pressures. Alternatively manual (R/L or 4–20 mA) flow demands can be used to manually set/control turbine header flows.

### Ratio/Limiter Algorithm

The control's ratio/limiting algorithm receives demand signals from the Speed/Load, P1 Extraction, and P2 Extraction PID controllers, then based on the entered turbine performance map calculates respective HP, IP, and LP valve positions to effectively de-couple the effects of each controlled parameter on the other. Four decoupling modes are available to match the 505DE control's response/operation to the specific application's requirements.

## Redundancy

The 505DE system is capable of running in a redundant master / standby configuration to provide higher availability. Synchronized memory assures that both CPUs use the same operating information in every rate group. If the master CPU becomes inoperable, full system control, including control of the I/O, is transferred to the standby CPU in less than 1 ms without affecting prime mover operation. After correcting the master CPU fault, the system can continue running on the standby CPU, or control of the system can be transferred back to the original master CPU. Annunciation of any control transfer is given through communication links.

### Input Signals

#### Power Source (Simplex or Redundant)

- AC/DC – Power Supply (88–132 Vac/47–63 Hz or 100–150 Vdc)
- HVAC – Power Supply (180–264 Vac/47–63 Hz)

#### Speed Signals (4)

Inputs can be configurable to accept signals from:

- MPUs (100–24 950 Hz)
- Proximity probes (0.5–24 950 Hz):

#### Discrete Inputs (48)

All discrete inputs can be configured to function as:

- Start & Stop signals
- Shutdown and Alarm signals
- Setpoint Raise/Lower signals
- Function Enable/Disable commands
- Breaker position indications signals
- Redundant Discrete Input signals

#### 4–20 mA Analog Inputs (16)

All analog input channels can be configured to function as:

- Extraction header pressure inputs
- Inlet and Exhaust header pressure inputs
- Remote PID setpoint inputs
- Generator Load and Synchronizer/Loadshare inputs
- Monitor Analog Input signals
- Redundant Analog Input signals

### Output Signals

#### Discrete Output Relays (24)

All discrete output relays can be configured to function as:

- Shutdown and Alarm relay outputs
- Controlling Mode indication relay outputs
- Speed and Analog Level indication relay outputs

#### Actuator Driver Outputs (4)

Actuator driver output signals are pre-defined as:

- V1 Actuator (4–20 mA or 20–200 mA)
  - V1 Actuator (4–20 mA or 20–200 mA, Split Range Apps)
  - V2 Actuator (4–20 mA or 20–200 mA)
  - V3 Actuator (4–20 mA)
  - \*\*V1 Actuator ( $\pm 200$  mA, Integrating Servo Cntrl)
  - \*\*V1 Actuator ( $\pm 200$  mA, Integrating Servo Cntrl, Split Range Apps)
  - \*\*V2 Actuator ( $\pm 200$  mA, Integrating Servo Cntrl)
  - \*\*V3 Actuator ( $\pm 200$  mA, Integrating Servo Cntrl)
  - Redundant Actuator outputs (with use of redundant modules)
- \*\* = Only available with long-chassis models

#### 4–20 mA Analog Outputs (8)

All 4-20mA Analog outputs can be configured to function as:

- System Meter readouts
- DCS Interface readouts

#### Communication Ports (3)

- (2) Ethernet ports (OPC or Modbus)
- (1) Serial RS-232, RS-422, RS-485 Modbus port

Technical Manual: 26361

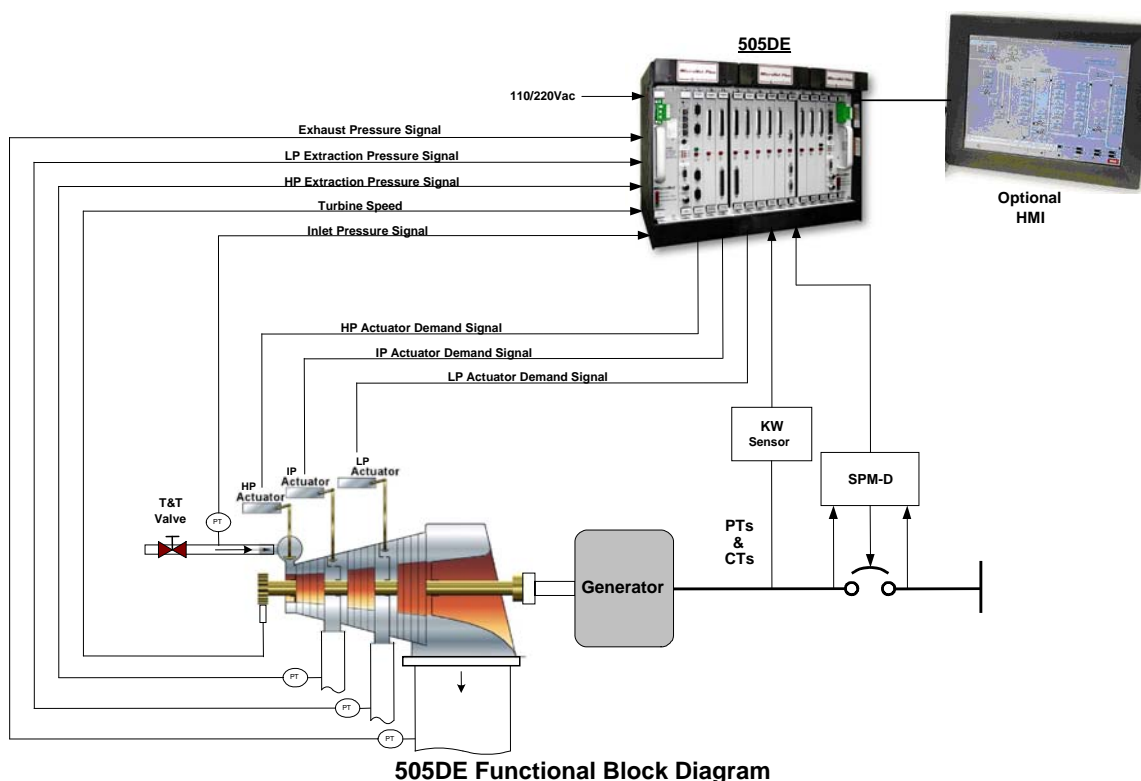

505DE Functional Block Diagram

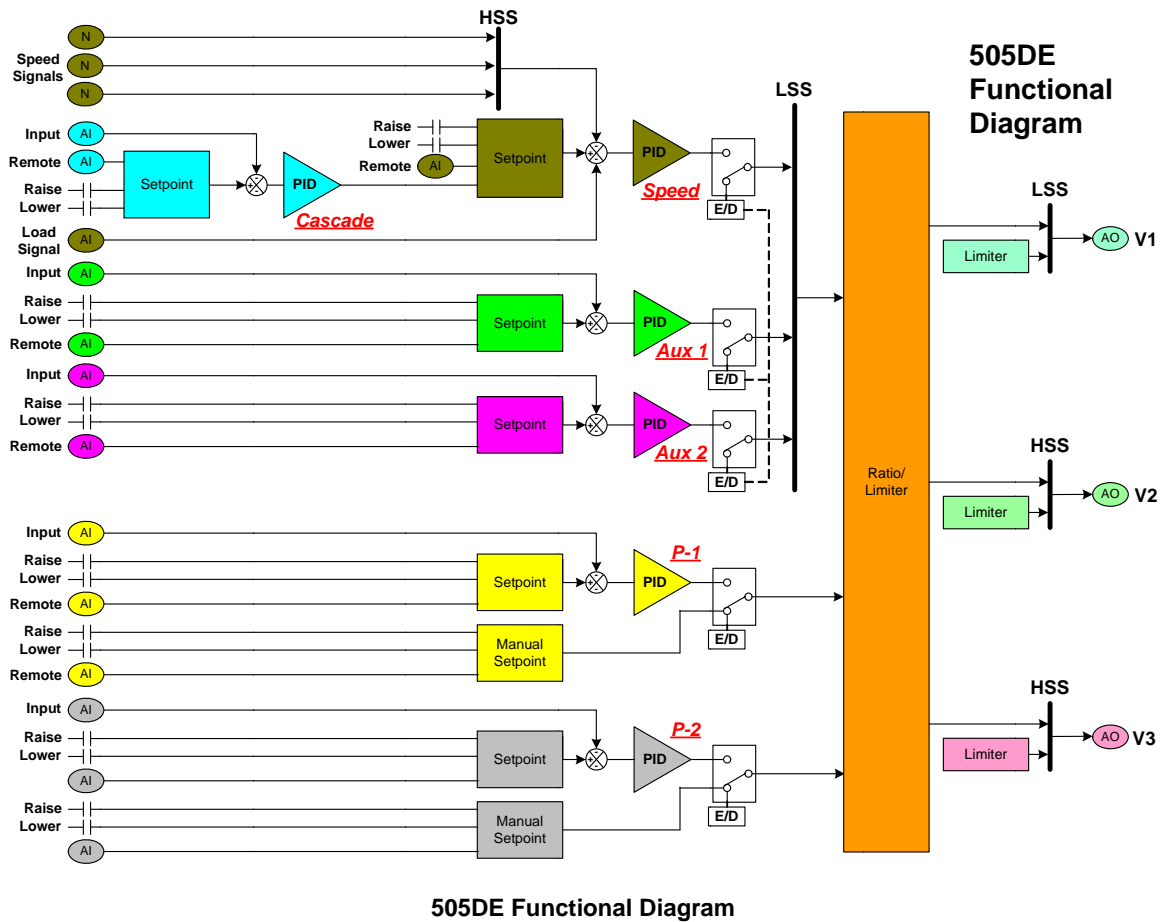

## Specifications

### Operating Conditions

Temperature:	0 to 55 °C (32 to 131 °F) ambient air temperature range
Shock:	US MIL-STD-810C, method 516.2-1, procedure 1B (15 G, 11 ms half-sine pulse)
Vibration:	Lloyd's ENV2 test #1
Emissions:	EN55011, Class A, Gr 1
Immunity:	EN50082-2

## Regulatory Compliance

Listings are limited only to those units bearing the appropriate Marking or Agency Identification.

European Compliance for CE Marking:

<b>EMC Directive:</b>	89/336/EEC
<b>Low Voltage Directive:</b>	2006/95/EC

North American Compliance:

<b>UL:</b>	UL Listed for Class I, Division 2, Groups A, B, C, & D, T3A at 65 °C surrounding air temperature. For use in Canada and the United States. UL File E156028
------------	---



PO Box 1519, Fort Collins CO, USA 80522-1519  
 1000 East Drake Road, Fort Collins CO 80525  
 Tel.: +1 (970) 482-5811 • Fax: +1 (970) 498-3058  
[www.woodward.com](http://www.woodward.com)

### Distributors & Service

Woodward has an international network of distributors and service facilities. For your nearest representative, call the Fort Collins plant or see the Worldwide Directory on our website.

This document is distributed for informational purposes only. It is not to be construed as creating or becoming part of any Woodward contractual or warranty obligation unless expressly stated in a written sales contract.

© Woodward 2003, All Rights Reserved

For more information contact:

2011/4/Colorado