

UG-25⁺

Governor

Description

The Woodward UG-25⁺ governor is a microprocessor-controlled, mechanical-hydraulic amplified, governor for controlling diesel, gas, and dual fuel engines, and steam turbines.

Enhanced control capabilities, such as start fuel and boost limiting schemes, are an integral part of the UG-25⁺ governor. The additional transient fuel limiting (jump-rate) improves the engine load acceptance and reduces transient emissions significantly.

This fast-acting, high-work-output governor has no need for any auxiliary devices such as a start booster or oil cooler. Two work output versions are available.

The UG-25⁺ offers speed control with software-selectable speed set points, dynamics, fuel limiting, and start behavior. All it takes is a PC to adjust and download configuration data.

Front panel and external speed settings make synchronization and load sharing easy for generator applications. A 4 mA to 20 mA speed setting is available for variable speed applications.

Adjustable droop permits load division and balancing among parallel operated prime movers. Droop can be set with a knob on the front panel between 0–10. The load limiter knob allows you to limit the governor output manually.

The UG-25⁺ uses a 1034 kPa (150 psi) internal operating pressure with an internal oil pump driven from the governor's drive shaft, available in either a keyed or serrated configuration. Oil pressure is maintained by a relief valve system with a drain to an internal oil sump.

Control features:

- State-of-the-art speed sensing and control algorithms
- Enhanced PID dynamics
- Configurable speed settings and adjustment rates
- Multiple fuel limiting algorithms, such as jump-rate, boost pressure, and start fuel limiting
- Comprehensive diagnostics for easy troubleshooting

The UG-25⁺ is a drop-in replacement for UG8 and 3161 governors and combines all the advantages of a traditional mechanical governor with the state-of-the-art control algorithms for optimal engine operation.



- Suitable for gasoline, gaseous, and diesel fueled engines
- Convenient front panel adjustments
- Speed setting with standard 4 mA to 20 mA signal or using raise/lower commands
- Easy setup and tuning using PC-based Service Tool
- Discrete output driver for status indication
- Isochronous or droop control
- Drop-in replacement for UG8 and 3161 governors
- 34 J (25 ft-lb) & 41 J (31 ft-lb) versions available
- Available with either a keyed or serrated drive shaft
- Marine Listed

Specifications

Governor

Power Supply	(18 to 32) V (dc), dual inputs
Power Consumption	Reverse polarity protection, 32 W max

Torque/Work Output (minimum):

Standard Version (0.625 inch diameter terminal shaft)	45.4 N·m (33.5 lb-ft) torque; 32.9 J (24.3 ft-lb) of work over 42 degrees
Increased Output Version (0.75 inch diameter terminal shaft)	55.5 N·m (40.9 lb-ft) torque; 40.2 J (29.6 ft-lb) of work over 42 degrees

Max. Continuous Speed	1700 rpm (gov. shaft) max (small pump); 1200 rpm (gov. shaft) max (large pump)
Hysteresis	1.0 % or less (measured over full terminal shaft travel)
Temperature Drift	1.0 % of full terminal shaft travel between 27 °C and 77 °C (80 °F and 170 °F)
Linearity	2.5 % or less (measured over full terminal shaft travel)
Ramp-up Rate	Configurable from 0.2 to 200 rpm/s (gov. shaft)
Steady State Speed Band	±0.25% of rated speed (under normal operating conditions)
Weight	28 kg (62 lb), dry weight
Customer Connections	Terminal blocks located inside front access plate

Governor Drive / Hydraulic System

Input Shaft Options	0.625 keyed drive shaft with 0.625-18 threads or 0.625-36 serrated
Output	42.2 ± 0.6 degrees rotary
Terminal Shaft Options	0.625-36 serration (standard), 0.750-36 serration (increased output version)
Drive Power Requirement	335 W (0.45 hp) max.
Internal Hydraulic Pressure	1034 kPa (150 psi)
Oil	Self-contained sump (2.1 L / 2.2 quart capacity). See Woodward Manual 25071, <i>Oils for Hydraulic Controls</i> , for oil recommendations.
Drive Speed	Available with either high or low speed pump High-speed pump: 500 rpm to 1700 rpm (gov. shaft) Low Speed pump: 350 rpm to 1200 rpm (gov. shaft)
Drive Rotation	Pump can be configured to operate in CW or CCW direction

Functions

Function Options	Start Fuel Limiter; Adjustable Max Fuel Stop; Jump and Rate Limiter; Position-based Gain curve; Manifold Air Pressure Biased Fuel Limiter, Analog set-point rate limit; separate Raise and Lower Rates; Start Gain
Programming Port I/O	Programmable with Windows GUI software and harness 4 mA to 20 mA analog speed setting; Analog Speed Set-point selector Raise, Lower, and Stop discrete inputs Analog Speed Set Enable discrete input 4 mA to 20 mA boost fuel limiter input; Boost Input selector Unit Healthy discrete out
Front Panel Functions	Raise and Lower speed set-point commands Stop command; Droop adjustment; Stability adjustment, Fuel-Limit adjustment
Front Panel Indications	Unit Healthy status indication, Speed Set-point mode indications (Raise/Lower or Analog)

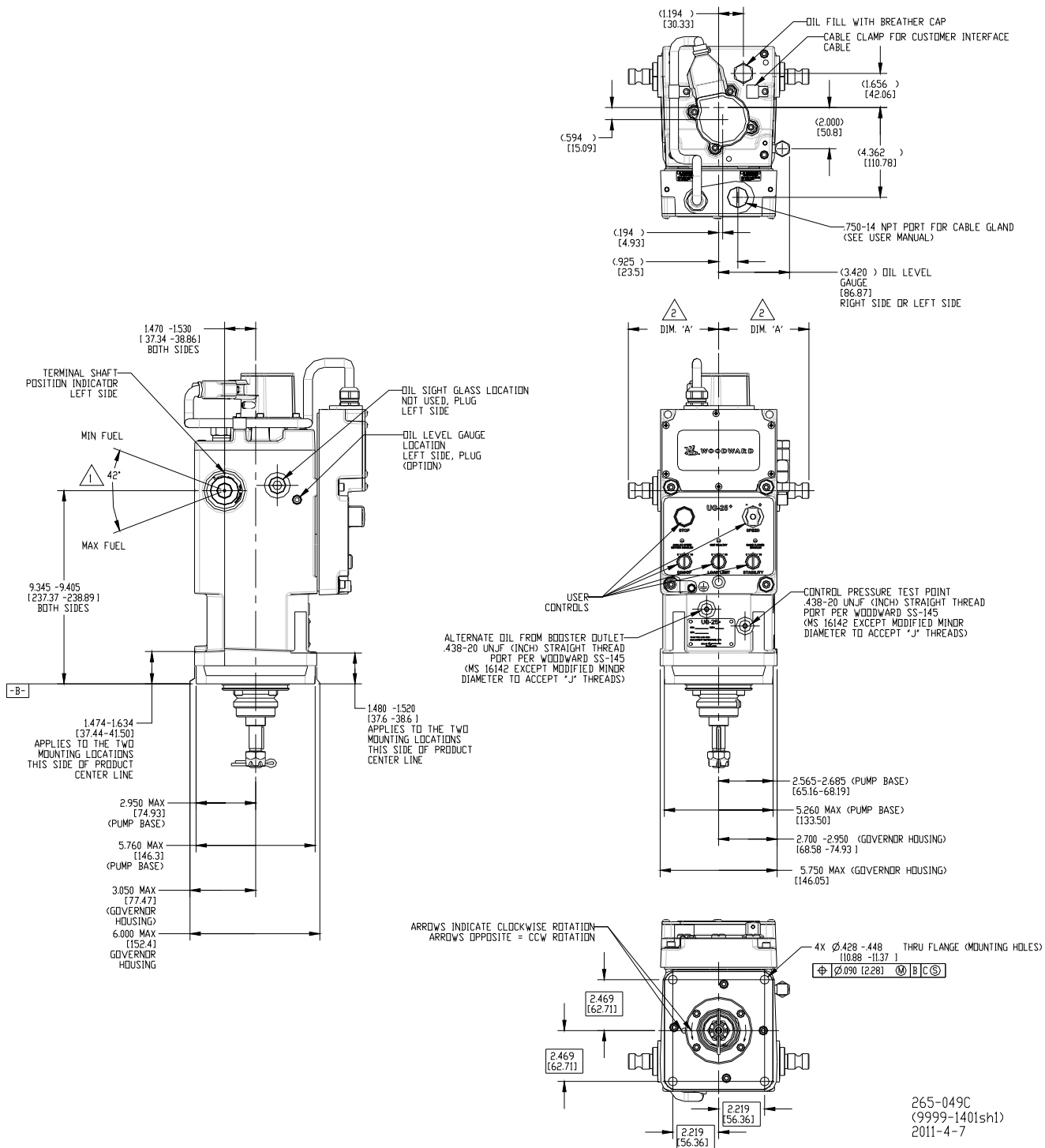

UG-25+ Outline Drawing (Do Not Use for Construction)

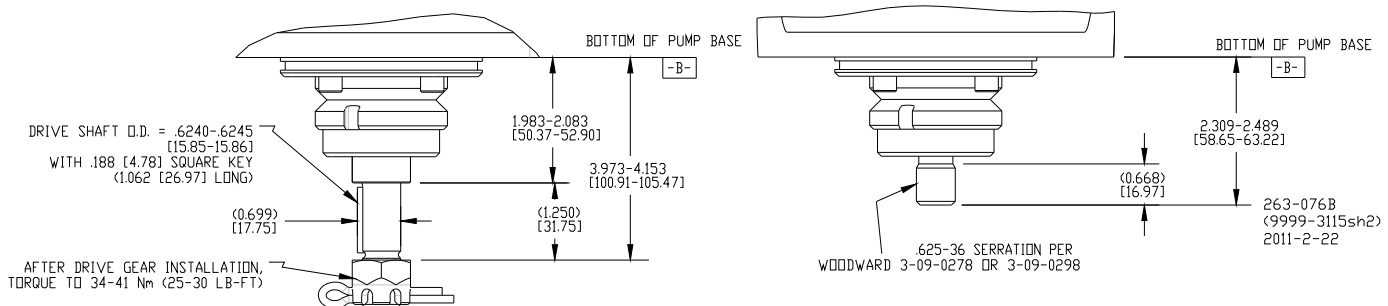

Drive Shaft Options

Specifications (continued)

Environment

Ambient Operating Temperature	0 °C to 55 °C (32 °F to 131 °F)
Governor Case Temperature	100 °C (212 °F) maximum
Storage Temperature	-40 °C to +85 °C (-40 °F to +185 °F), limited by electronics
EMC	EN61000-6-2: Immunity for Industrial Environments EN61000-6-4: Emissions for Industrial Environments
Humidity	US MIL-STD 810E, Method 507.3, Procedure III
Shock	MS1-40G 11 ms saw tooth
Vibration Validation	Power Spectral Density (PSD) must not exceed the level or frequency as shown in the curve while the governor is running on a loaded engine, as measured at governor base.

UG25+ Maximum Allowed Application Vibration PSD vs. Frequency

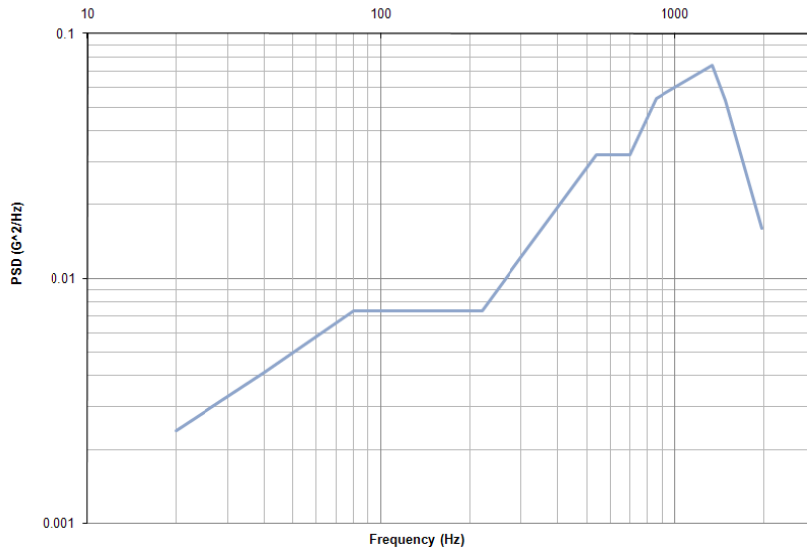

Frequency (Hz)	Allowed PSD Level (G ² /Hz)
20	0.00240
40	0.00414
80	0.00736
220	0.00736
540	0.03197
700	0.03197
860	0.05453
1340	0.07452
1480	0.05339
1960	0.01595

Thermal Shock	SAE J1455, Paragraph 4.1.3.2
Ingress Protection	IP45 for entire unit. IP56 for User Interface per EN60529 and only if proper cable glands are used as described in the technical manual.

Regulatory Compliance (PENDING)

CE	Compliant with EMC Directive 89/336/EEC
Marine	Det Norske Veritas American Bureau of Shipping Bureau Veritas Germanischer Lloyd Korean Register of Shipping Lloyd's Register Nippon Kaiji Kyokai Registro Italiano Navale
Other	Compliant as a component with Machinery Directive 98/37/EC

Technical Manual 26579



PO Box 1519, Fort Collins CO, USA 80522-1519
1000 East Drake Road, Fort Collins CO 80525
Tel.: +1 (970) 482-5811 • Fax: +1 (970) 498-3058
www.woodward.com

Distributors & Service

Woodward has an international network of distributors and service facilities. For your nearest representative, call the Fort Collins plant or see the Worldwide Directory on our website.

This document is distributed for informational purposes only. It is not to be construed as creating or becoming part of any Woodward contractual or warranty obligation unless expressly stated in a written sales contract.

© Woodward 2006, All Rights Reserved

For more information contact:

2011/4/Colorado